



## شرکت آسان راه البرز

با 40 سال تجربه در زمینه ی واردات ماشین آلات معدنی، راهسازی و صنعتی و با استفاده از مدیران خبره، کارشناسان مجرب و پرسنل با تجربه آموزش دیده از فعالترین شرکت های تجاری در ایران می باشد. این شرکت در سال 1389 موفق به اخذ نمایندگی رسمی از شرکت هیوندای کره جنوبی و نمایندگی انحصاری محصولات اوردایم برای واردات، فروش و خدمات پس از فروش ماشین آلات سنگین، راهسازی، معدنی و صنعتی در ایران گردید.

این شرکت با توجه به نیاز مشتریان و محیط های کاری موجود اقدام به واردات انواع ماشین آلات راهسازی از قبیل لودر چرخ لاستیکی، بیل هیدرولیکی چرخ لاستیکی و چرخ زنجیری و انواع لیفتراک با بازه تناژی بالا و انواع چکش های هیدرولیکی و انواع ژنراتورهای برق (دیزلی و دوگانه سوز) نموده است و هر دوره با توجه به درخواستها بر تنوع محصولات خود اضافه میکند.



## STANDARD EQUIPMENT

ISO Standard cabin
All-weather steel cab with 360° visibility
Safety glass windows
Rise-up type windshield wiper
Sliding fold-in front window
Sliding side window(LH)
Lockable door
Hot & cool box
Storage compartment & Ashtray
Cabin roof-steel cover
Radio & USB Player
12 volt power outlet (24V DC to 12V DC converter)
Computer aided power optimization (New CAPO) system
3-power mode, 2-work mode, user mode
Auto deceleration & one-touch deceleration system
Auto warm-up system
Auto overheat prevention system
Automatic climate control
Air conditioner & heater
Defroster
Self-diagnostics system
Starting Aid (air grid heater) for cold weather
Centralized monitoring
LCD display
Engine speed or Trip meter/Accel.
Clock
Gauges
Fuel level gauge
Engine coolant temperature gauge
Hyd. oil temperature gauge
Warnings
Check Engine
Communication error
Low battery
Air cleaner clogging
Indicators
Max power
Low speed/High speed
Fuel warmer
Auto idle
Door and cab locks, one key
Two outside rearview mirrors
Fully adjustable suspension seat with seat belt
Pilot-operated slidable joystick
Two front working lights
Electric horn
Batteries (2 x 12V x 100 AH)
Battery master switch
Removable clean-out dust net for cooler
Automatic swing brake
Removable reservoir tank
Fuel pre-filter with fuel warmer
Boom holding system
Arm holding system
Accumulator for lowering work equipment
Electric Transducer
Lower frame under cover (Normal)
Tires-dual (10.00-20-14PR)
Travel alarm

## OPTIONAL EQUIPMENT

Fuel filler pump (35 L/min)
Beacon lamp
Single-acting piping kit (breaker, etc.)
Double-acting piping kit (clamshell, etc.)
Quick coupler
Booms
5.1m, 16' 9"
Arms
2.2m, 7' 3"
2.6m, 8' 6"
3.1m, 10' 2"
Climate control
Air conditioner only
Heater only
Cabin FOPS/FOG (ISO/DIS 10262 Level 2)
FOPS (Falling Object Protective Structure)
FOG (Falling Object Guard)
Cabin guard-Front
Wire net
Fine net
Cabin lights
Cabin front window rain guard
Sun visor
Undercarriage
Rear outrigger
Rear dozer and front outrigger
Rear and front outrigger
Rear outrigger and front dozer
Rear dozer
Lower frame under cover (Additional)
Pre-heating system, coolant
Tool kit
Operator suit
Rearview camera
Seat
Mechanical suspension seat with heater
Tires - dual (10.00 - 20 solid)
Fenders (Mudguards)
Hi-mate (Remote Management System)
Air compressor
Rear work Lamp

- \* Standard and optional equipment may vary. Contact your Hyundai dealer for more information. The machine may vary according to International standards.
- \* The photos may include attachments and optional equipment that are not available in your area.
- \* Materials and specifications are subject to change without advance notice.
- \* All imperial measurements rounded off to the nearest pound or inch.

PLEASE CONTACT

**HYUNDAI**  
HEAVY INDUSTRIES CO.,LTD.  
**CONSTRUCTION EQUIPMENT**

Head Office  
1000 BANGEOJINSUNHWAN-DORO, DONG-GU, ULSAN, 682-792, KOREA  
TEL:(82)52-202-7722, 9807 FAX:(82)52-202-7720



We build a better future

**Robex**  
**180w-95**

With Tier 2 Engine installed



\*Photo may include optional equipment.



# Pride at Work

Hyundai Heavy Industries strives to build state-of-the-art earthmoving equipment to give every operator maximum performance, more precision, versatile machine preferences, and proven quality. Take pride in your work with Hyundai!

## Robex 180w-95

### Machine Walk-Around

#### Engine Technology

Proven and reliable, fuel efficient Mitsubishi Tier II S6S-DT engine  
Low noise / Auto engine warm up feature / Anti-restart feature

#### Hydraulic System Improvements

New patented hydraulic control system for improved controllability / Improved control valve design for added efficiency and smoother operation / New auto boom and swing priority system for optimum speed / New auto power boost feature for additional power when needed / Improved arm-in flow regeneration system for added speed and efficiency

#### Pump Compartment

Industry-leading, powerful, reliable Kawasaki designed, variable volume in-line axial piston pumps  
New compact solenoid block equipped with 3 solenoid valves, 1 EPPR valve, 1 check valve accumulator and pilot filter-controls safety lock, power boost, arm-in regeneration control, boom priority (swing logic valve control)  
Remotely mounted fuel, engine oil and case drain filters for maximum convenience while servicing

#### Carrier

Heavy duty carrier frame with two speed powershift transmission  
Heavy duty drive line and axles / Front axle oscillation +/- 7 degrees with ram lock  
Wet disc brake (front & rear) / Automatic parking brake - spring applied, hydraulically released

#### Improved Steering Column

Slim-profile steering column capable of telescoping 60 mm and tilting 30 degrees

#### Enhanced Operator Cab

##### Improved visibility

Enlarged cab with improved visibility  
Larger right-side glass, now one piece, for better right visibility  
Safety glass windows on all sides - less expensive than (polycarbonate) and won't scratch or fade  
Reduced front window seam for improved operator view

##### Improved Cab Construction

New steel tube construction for added operator safety, protection and durability  
New window open/close mechanism designed with cable and spring lift assist and single latch release

##### Improved Suspension Seat / Console Assembly

Ergonomic joysticks with auxiliary control buttons for attachment use, now with new sleek styling  
Adjustable arm rests - turn dial to raise or lower for optimum comfort

##### Advanced 7" Color Cluster

New color LCD display with easy-to-read digital gauges for hydraulic oil temperature, water temperature, and fuel. Simplified design makes adjustment and diagnostics easier. Also, new enhanced features such as rear-view camera are integrated into monitor  
3 power modes : (P) Power, (S) Standard, (E) Economy, 2 work modes : Dig & Attachment, (U) User mode for operator preference  
Enhanced self-diagnostic features with GPS/satellite technology  
One pump flow or two pump flow for optional attachment now selectable through the cluster  
New anti-theft system with password capability  
Boom speed and arm regeneration are selectable through the monitor  
Auto power boost is now available - selectable (on/off) through the monitor  
Powerful air conditioning and heat with auto climate control, 20% more heat and air output than 7 series!  
Hi-Mate (Remote Management System) works through GPS/Satellite technology to ultimately provide better customer service and support

\*Photo may include optional equipment.



# Preference

Operating a 9S Series is unique to every operator. Operators can fully customize their work environment and operating preferences to fit their individual needs.



\*Photo may include optional equipment.



## Wide Cabin with Excellent Visibility

The newly designed cabin was conceived for more space, a wider field of view and operator comfort. Special attention was given to a clear, open and convenient interior with plenty of visibility on the machine surroundings and the job at hand. This well balanced combination of precision aspects put the operator in the perfect position to work safely and securely.

## Operator Comfort

In a 9S series cabin you can easily adjust the seat, console and armrest settings to best suit your personal operating preferences. Seat and console position can be set together and independent from each other. Improved steering wheel telescope and tilt functions provide operators improved access. A fully automatic, high capacity airconditioning system maintains a constant preferred temperature.



## Reduced Stress

Work is stressful enough. Your work environment should be stress free. Hyundai's 9S Series provides improved cab amenities, additional space and a comfortable seat to minimize stress to the operator. A powerful climate control system provides the operator with optimum air temperature. An advanced audio system with USB player, AM/FM stereo is perfect for listening to music favorites.



## Operator - Friendly Cluster

The advanced new cluster with 7 inch wide color LCD screen and toggle switch allows the operator to select his personal machine preferences. Power and work mode selection, self diagnostics, optional rear-view camera, maintenance check lists, start-up machine security were integrated into the cluster to make the machine more versatile and the operator more productive.





# Precision

Innovative hydraulic system technologies make the 9S Series excavator fast, smooth and easy to control.



## Computer Aided Power

The engine horsepower and hydraulic horsepower together in unison through the advanced CAPO(Computer Aided Power Optimization) system, flow for the job at hand. Operator can set their own preferences for boom or swing priority, power mode selection and optional work tools at the touch of a button.

The CAPO system also provides complete self diagnostic features and digital gauges for important information like hydraulic oil temperature, water temperatures and fuel level. This system interfaces with multiple sensors placed throughout the hydraulic system as well as hydraulic flow.

### Power Mode

P (Power Max) mode maximizes machine speed and power for mass production. S (Standard) mode provides a reduced, fixed rpm for optimum performance and improved fuel economy. For maximum fuel savings and improved control, E (Economy) mode provides precise flow based on load demand. Three unique power modes provide the operator with custom power, speed and fuel economy.

### Work Mode

The work mode allows the operator to select single flow attachments like a hydraulic breaker or bi-directional flow attachments like a crusher. Flow settings unique to each attachment can be programmed from within the cluster.

### User Mode

Some jobs require more precise machine settings. Using the versatile U (User) mode, the operator can customize engine speed, pump output, idle speed and other machine settings for the job at hand.

## Improved Hydraulic System



To achieve optimum precision, Hyundai redesigned the hydraulic system to provide the operator with super fine touch and improved controllability. Improved pump flow control reduces flow when controls are not being used to minimize fuel consumption.

Improved spool valves in the control valve are engineered to provide more precise flow to each function with less effort.

Improved hydraulic valves, precision-designed variable volume piston pumps, fine-touch pilot controls, and enhanced travel functions make any operator running a 9S Series look like a smooth operator. Newly improved features

include arm-in and boom-down flow regeneration, improved control valve technology and innovative auto boom and swing priority for optimal performance in any application.

## Auto Boom-swing Priority

This smart function automatically and continuously looks the ideal hydraulic flow balance for the boom and swing motions of the machine. The advanced CAPO system monitors the hydraulic system and adjusts its settings to maximize performance and productivity.



\*Photo may include optional equipment.



# Performance

9S Series is designed for maximum performance to keep the operator working productively.



\*Photo may include optional equipment.

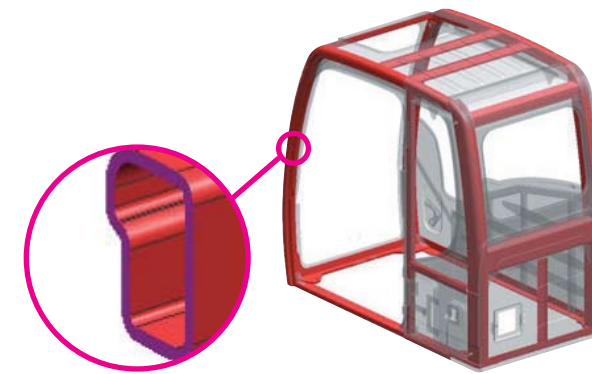

## Structural Strength

The 9S series cabin structure has been fitted with stronger but slimmer tubing for more safety and better visibility. Low-stress and high strength steel was integrally welded to form a strong and stable lower frame. Structural durability was evaluated and tested by means of FEM (Finite Elements Method) analysis and long-term durability tests.



## Improved Durability

9S series excavators are equipped with stainless spring guards to protect the hoses from external damages. Both dozer and outrigger are equipped with cylinder guards for added protection.

## Improved Travel System

A new auto ram lock system is available to improve operating safety. A new optional forward / reverse travel pedal control allows operators to choose to use the travel pedal control while in work mode or lever control when in travel mode.



Auto ram lock system

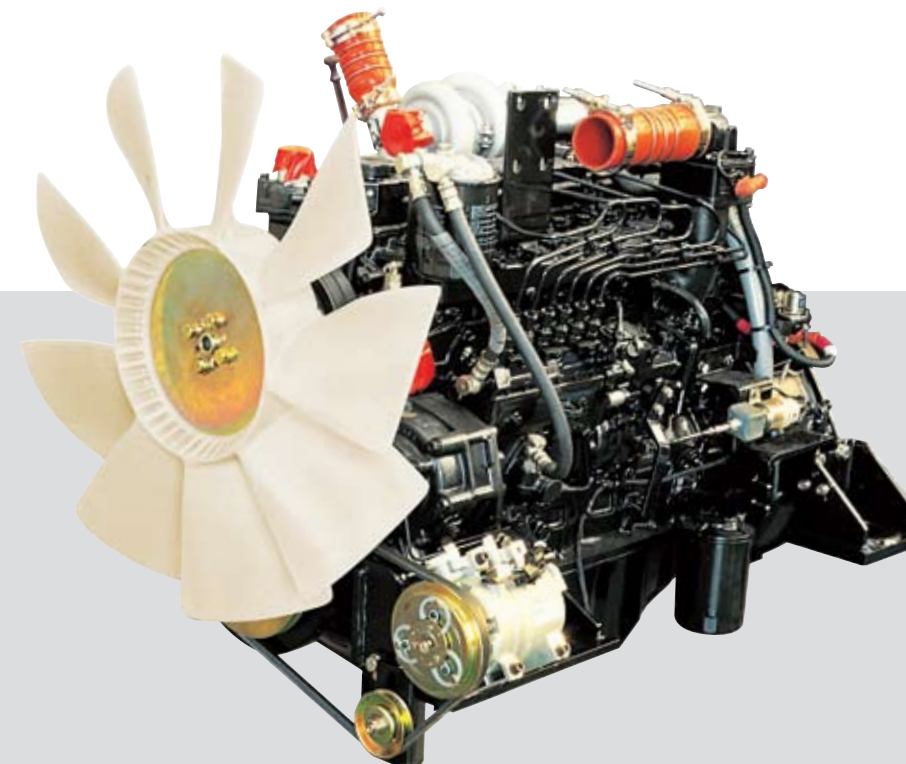

## Mitsubishi S6S-DT Engine

Mitsubishi S6S-DT engine is ideal solution for the toughest work environment. The engine is built from a cast iron, skirted block with main bearing support between each cylinder. This combination provides maximum strength, rigidity, and crankshaft support. Special liquid cooling results in uniform temperature distribution.



# Profitability

9S Series is designed to maximize profitability through improved efficiencies, enhanced service features and longer life components.



\*Photo may include optional equipment.

## Fuel Efficiency

9S Series excavators are engineered to be extremely fuel efficient. New innovations like two-stage auto decel system and the new economy mode help to conserve fuel and reduce the impact on the environment.



## Hi-mate (Remote Management System)

Hi-mate, Hyundai's proprietary remote management system, provides operators and dealer service personnel access to vital service and diagnostic information on the machine from any computer with internet access. Users can pinpoint machine location using digital mapping and set machine work boundaries, reducing the need for multiple service calls. Hi-mate saves time and money for the owner and dealer by promoting preventative maintenance and reducing machine downtime.



## Easy Access

Ground-line access to filters, lube fittings, fuses, machine computer components and wide open compartments makes service more convenient on the 9S Series.



## Long-Life Components

9S series excavators were designed with bushings designed for long-life lube intervals (250 hrs) & polymer shims (wear resistant, noise reducing), long-life hydraulic filters (1,000hrs), long-life hydraulic oil (5,000hrs), more efficient cooling systems and integrated preheating systems which extend service intervals, minimize operating costs and reduce machine down time.

# Specifications

## ENGINE

MODEL		MITSUBISHI S6S-DT	
Type		Water cooled, 4 cycle diesel 6-cylinders in line, direct injection, Turbocharged, charger air cooled low emission	
Rated flywheel horsepower	SAE	J1995 (gross) J1349 (net)	126 HP (94kW) at 2,100 rpm 116 HP (87kW) at 2,100 rpm
	DIN	6271/1 (gross) 6271/1 (net)	128 PS (94kW) at 2,100 rpm 118 PS (87kW) at 2,100 rpm
Max. torque		42.5 kgf-m(307 lbf-ft) at 1,400 rpm	
Bore X stroke		94 x 120 mm (3.70" x 4.72")	
Piston displacement		4,996 cc (305 in <sup>3</sup> )	
Batteries		2 x 12 V x 100 AH	
Starting motor		24V-5.0 kW	
Alternator		24V-50 Amp	

## HYDRAULIC SYSTEM

MAIN PUMP	
Type	Two variable displacement piston pumps
Rated flow	2 X 172 L /min (45.4 US gpm/37.8 UK gpm)
Sub-pump for pilot circuit	Gear pump

Cross-sensing and fuel saving pump system

HYDRAULIC MOTORS	
Travel	Variable displacement bent-axis axial pistons motor
Swing	Axial piston motor with automatic brake

RELIEF VALVE SETTING	
Implement circuits	350 kgf/cm <sup>2</sup> (4,970 psi)
Travel	380 kgf/cm <sup>2</sup> (5,400 psi)
Power boost (boom, arm, bucket)	380 kgf/cm <sup>2</sup> (5,400 psi)
Swing circuit	285 kgf/cm <sup>2</sup> (4,050 psi)
Pilot circuit	40 kgf/cm <sup>2</sup> (570 psi)
Service valve	Installed

HYDRAULIC CYLINDERS	
No. of cylinder bore X stroke	Boom : 2-115 x 1,090 mm (4.5" x 42.9")
	Arm : 1-120 x 1,355 mm (4.7" x 53.3")
	Bucket : 1-110 x 995 mm (4.3" x 39.2")
	Blade : 2-110 x 235 mm (4.3" x 9.3")
	Outrigger : 2-125 x 463 mm (4.9" x 18.2")

## DRIVES & BRAKES

4-wheel hydrostatic drive. Constant mesh, helical gear transmission provides 2 forward and reverse travel speeds.

Max. drawbar pull		11,600 kgf (25,570 lbf)
Travel speed	1st	8.4 km/h (5.2 mph)
	2nd	30 km/h (18.6 mph)
Gradeability		35%(70 %)

Parking brake : Independent dual brake, front and rear axle full hydraulic power brake.

- Spring released and hydraulic applied wet type multiple disk brake.
- Transmission is locked at neutral position for parking, automatically.

## CONTROL

Pilot pressure operated joysticks and pedals with detachable lever provide almost effortless and fatigueless operation.

Pilot control	Two joysticks with one safety lever (LH): Swing and arm, (RH): Boom and bucket (ISO)
Engine throttle	Electric, Dial type

## AXLE & WHEEL

Full floating front axle is supported by center pin for oscillation. It can be locked by oscillation lock cylinders. Rear axle is fixed on the lower chassis.

Tires	10.00-20-14PR, Dual(tube type)
(optional)	10.00-20, Dual(solid type)

## SWING SYSTEM

Swing motor	Fixed displacement axial pistons motor
Swing reduction	Planetary gear reduction
Swing bearing lubrication	Grease-bathed
Swing brake(option)	Multi wet disc
Swing speed	11 rpm

## STEERING SYSTEM

Hydraulically actuated, orbitrol type steering system actuates on front wheels through the steering cylinders.

Min. turning radius	6,300 mm(20' 8")
---------------------	------------------

## COOLANT & LUBRICANT CAPACITY

Re-filling	liter	US gal	UK gal	
Fuel tank	270.0	71.3	59.4	
Engine coolant	22.0	5.8	4.8	
Engine oil	16.5	4.4	3.6	
Swing device - gear oil	5.0	1.3	1.1	
Axle	Front	15.5	4.1	3.4
	Rear	17.5	4.6	3.8
Hydraulic system (including tank)		210.0	55.5	46.2
Hydraulic tank		124.0	32.8	27.3

## UNDERCARRIAGE

Reinforced box-section frame is all-welded, low-stress. Dozer blade and outriggers are available. A pin-on design.

Dozer blade	A very useful addition for leveling and back filling or clean-up work.
Outrigger	Indicated for max. operation stability when digging and lifting. Can be mounted on the front or the rear.

## OPERATING WEIGHT (APPROXIMATE)

Operating weight, including 5,100mm (16' 9") Mono boom, 2,600mm (8' 6") arm, SAE heaped 0.89m<sup>3</sup> (1.16yd<sup>3</sup>) backhoe bucket, lubricant, coolant, full fuel tank, hydraulic tank and the standard equipment.

MAJOR COMPONENT WEIGHT	
Upperstructure	4,590 kg (10,120 lb)
Mono boom(with arm cylinder)	1,240 kg (2,730 lb)

OPERATING WEIGHT	
Undercarriage	Mono boom
Rear dozer blade	17,300 kg (38,140 lb)
Rear outrigger	17,450 kg (38,470 lb)
Front outrigger and rear blade	18,420 kg (40,610 lb)
Front blade and rear outrigger	18,360 kg (40,480 lb)
Four outrigger	18,600 kg (41,010 lb)

## BUCKETS

All buckets are welded with high-strength steel.

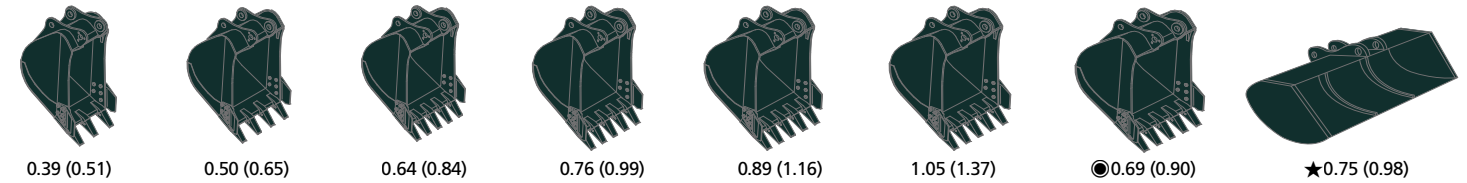

SAE heaped m<sup>3</sup> (yd<sup>3</sup>)

Capacity m <sup>3</sup> (yd <sup>3</sup> )		Width mm (in)		Weight kg (lb)	Recommendation mm (ft-in)		
SAE heaped	CECE heaped	Without sidecutters	With sidecutters		5,100 (16' 9") Mono Boom		
				2,200 (7' 3") Arm		2,600 (8' 6") Arm	3,100 (10' 2") Arm
0.39 (0.51)	0.34(0.44)	620(24.4)	740(29.1)	410(900)	●	●	●
0.50 (0.65)	0.44(0.58)	760(29.9)	880(34.6)	470(1040)	●	●	●
0.64 (0.84)	0.55(0.72)	920(36.2)	1,040(40.9)	510(1120)	●	●	●
0.76 (0.99)	0.65(0.85)	1,060(41.7)	1,180(46.5)	570(1260)	●	●	●
0.89 (1.16)	0.77(1.01)	1,220(48.0)	1,340(52.8)	610(1340)	●	●	●
1.05 (1.37)	0.90(1.18)	1,400(55.1)	1,520(59.8)	680(1500)	■	■	■
● 0.69 (0.90)	0.62(0.81)	990(39.0)	-	700(1540)	●	●	●
★ 0.75 (0.98)	0.65(0.85)	1,800(70.9)	-	540(1190)	●	●	●

- Heavy duty bucket
- ★ Ditching bucket

- : Applicable for materials with density of 2,000 kg /m<sup>3</sup> (3,370 lb/ yd<sup>3</sup>) or less
- : Applicable for materials with density of 1,600 kg /m<sup>3</sup> (2,700 lb/ yd<sup>3</sup>) or less
- ▲ : Applicable for materials with density of 1,100 kg /m<sup>3</sup> (1,850 lb/ yd<sup>3</sup>) or less

## ATTACHMENT

Boom and arms are welded with a low-stress, full-box section design. 5.1m (16' 9") boom, and 2.2m (7' 3"), 2.6m (8' 6"), 3.1m (10' 2") arms.

## DIGGING FORCE

Boom	Length	mm (ft-in)	5,100 (16' 9")			Remarks
	Weight	kg (lb)	1,240 (2,730)			
Arm	Length	mm (ft-in)	2,200 (7' 3")	2,600 (8' 6")	3,100 (10' 2")	
	Weight	kg (lb)	750 (1,560)	810 (1,790)	890 (1,960)	
Bucket digging force	SAE	kN	107.9 [117.2]	107.9 [117.2]	107.9 [117.2]	[ ]: Power Boost
		kgf	11,000 [11,940]	11,000 [11,940]	11,000 [11,940]	
		lbf	24,250 [26,330]	24,250 [26,330]	24,250 [26,330]	
	ISO	kN	123.6 [134.2]	123.6 [134.2]	123.6 [134.2]	
		kgf	12,600 [13,680]	12,600 [13,680]	12,600 [13,680]	
		lbf	27,780 [30,160]	27,780 [30,160]	27,780 [30,160]	
Arm crowd force	SAE	kN	87.2 [94.7]	77.3 [83.9]	69.0 [74.9]	
		kgf	8,890 [9,650]	7,880 [8,560]	7,030 [7,630]	
		lbf	19,600 [21,280]	17,270 [18,860]	15,500 [16,830]	
	ISO	kN	91.0 [98.8]	80.3 [87.2]	71.4 [77.5]	
		kgf	9,280 [10,080]	8,190 [8,890]	7,280 [7,900]	
		lbf	20,460 [22,210]	18,060 [19,600]	16,050 [17,430]	

Note: Boom weight includes arm cylinder, piping, and pin

Arm weight includes bucket cylinder, linkage, and pin



# Dimensions & Working Range

## R180W-9S DIMENSIONS

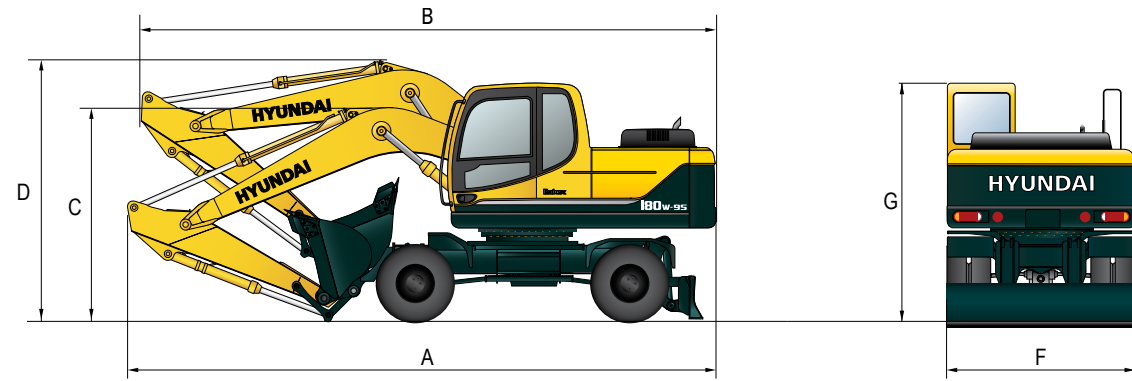

Unit : mm (ft - in)

Mono Boom	5,100(16' 9")		
Arm	2,200 (7' 3")	2,600 (8' 6")	3,100 (10' 2")
<b>A</b> Overall length of shipping position	8,650 (28' 5")	8,730 (28' 8")	8,760 (28' 9")
<b>B</b> Overall length of traveling position	8,590 (28' 2")	8,400 (27' 7")	8,480 (27' 10")
<b>C</b> Height of attachment (shipping position)	3,060 (10' 0")	3,020 (9' 11")	3,150 (10' 4")
<b>D</b> Height of attachment (traveling position)	3,610 (11' 10")	3,940 (12' 11")	3,900 (12' 10")
<b>F</b> Overall width	2,500 (8' 2")	2,500 (8' 2")	2,500 (8' 2")
<b>G</b> Height of cabin	3,190 (10' 6")	3,190 (10' 6")	3,190 (10' 6")

## R180W-9S WORKING RANGE

Unit : mm (ft - in)

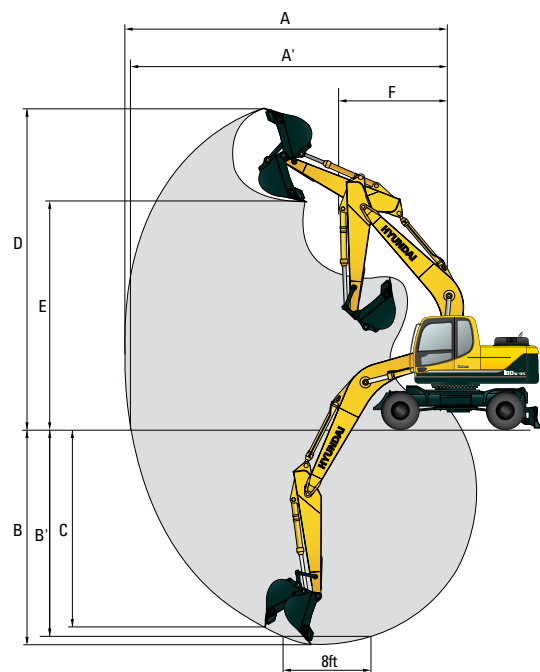

Boom length	5,100 (16' 9")		
Arm length	2,200 (7' 3")	2,600 (8' 6")	3,100 (10' 2")
<b>A</b> Max. digging reach	8,690 (28' 6")	9,020 (29' 7")	9,450 (31' 0")
<b>A'</b> Max. digging reach on ground	8,480 (27' 10")	8,810 (28' 11")	9,250 (30' 4")
<b>B</b> Max. digging depth	5,420 (17' 9")	5,820 (19' 1")	6,320 (20' 9")
<b>B'</b> Max. digging depth (8' level)	5,200 (17' 1")	5,620 (18' 5")	6,130 (20' 1")
<b>C</b> Max. vertical wall digging depth	4,890 (16' 1")	5,140 (16' 10")	5,470 (17' 11")
<b>D</b> Max. digging height	8,990 (29' 6")	9,070 (29' 9")	9,220 (30' 3")
<b>E</b> Max. dumping height	6,350 (20' 10")	6,460 (21' 2")	6,620 (21' 9")
<b>F</b> Min. swing radius	3,180 (10' 5")	3,170 (10' 5")	3,160 (10' 4")

# Undercarriage

R180W-9S WITH REAR DOZER AND FRONT REST

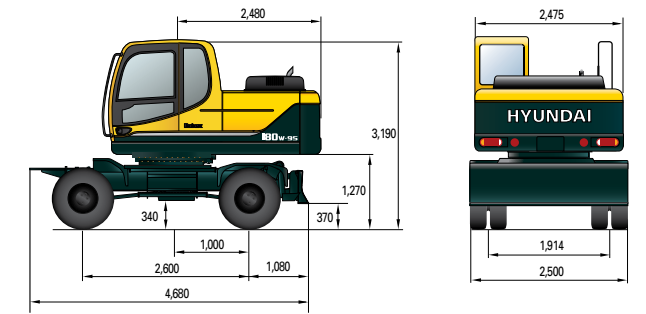

R180W-9S WITH REAR OUTRIGGER AND FRONT REST

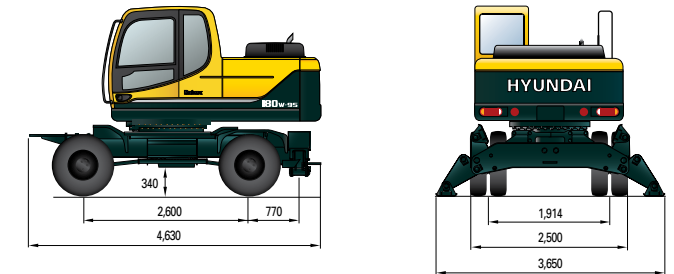

R180W-9S WITH REAR DOZER AND FRONT OUTRIGGER

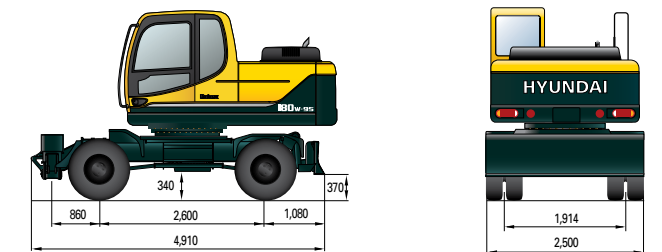

R180W-9S WITH REAR AND FRONT OUTRIGGER

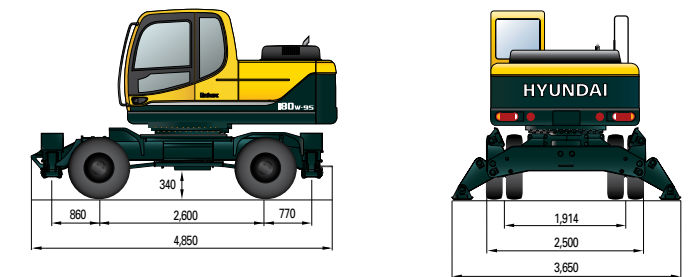

R180W-9S WITH REAR OUTRIGGER AND FRONT DOZER

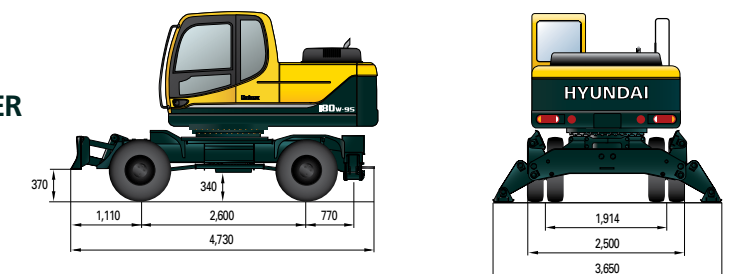



# Lifting Capacity

## R180W-9S

Rating over-front Rating over-side or 360 degree

Boom : 5.1 m (16' 9") / Arm : 2.2 m (7' 3") / Bucket : 0.76 m<sup>3</sup> (0.99 yd<sup>3</sup>) SAE / Outrigger and dozer blade down(CWT 2750kg, Front Position)

Load point height m (ft)		Load radius								At max. reach		
		1.5 m (5 ft)		3.0 m (10 ft)		4.5 m (15 ft)		6.0 m (20 ft)		Capacity		Reach
												m (ft)
7.5 m (25 ft)	kg									*3710	*3710	5.89
	lb									*8180	*8180	(19.3)
6.0 m (20 ft)	kg							*3340	*3340	*3660	3110	7.15
	lb							*7360	*7360	*8070	6860	(23.5)
4.5 m (15 ft)	kg					*4730	*4730	*4170	4110	*3690	2580	7.86
	lb					*10430	*10430	*9190	9060	*8140	5690	(25.8)
3.0 m (10 ft)	kg			*9740	*9740	*6000	*6000	*4690	3950	*3770	2350	8.19
	lb			*21470	*21470	*13230	*13230	*10340	8710	*8310	5180	(26.9)
1.5 m (5 ft)	kg					*7180	5940	*5230	3790	*3860	2300	8.19
	lb					*15830	13100	*11530	8360	*8510	5070	(26.9)
Ground	kg			*7660	*7660	*7720	5740	*5540	3670	*3940	2430	7.87
Line	lb			*16890	*16890	*17020	12650	*12210	8090	*8690	5360	(25.8)
-1.5 m (-5 ft)	kg	*7650	*7650	*11110	*11110	*7510	5690	*5380	3640	*3950	2830	7.18
	lb	*16870	*16870	*24490	*24490	*16560	12540	*11860	8020	*8710	6240	(23.6)
-3.0 m (-10 ft)	kg	*12010	*12010	*9250	*9250	*6410	5780			*3660	*3660	5.95
	lb	*26480	*26480	*20390	*20390	*14130	12740			*8070	*8070	(19.5)

Boom : 5.1 m (16' 9") / Arm : 2.2 m (7' 3") / Bucket : 0.76 m<sup>3</sup> (0.99 yd<sup>3</sup>) SAE / Outrigger and dozer blade up(CWT 2750kg, Front Position)

Load point height m (ft)		Load radius								At max. reach		
		1.5 m (5 ft)		3.0 m (10 ft)		4.5 m (15 ft)		6.0 m (20 ft)		Capacity		Reach
												m (ft)
7.5 m (25 ft)	kg									*3710	2790	5.89
	lb									*8180	6150	(19.3)
6.0 m (20 ft)	kg							*3340	2610	3320	1910	7.15
	lb							*7360	5750	7320	4210	(23.5)
4.5 m (15 ft)	kg					*4730	4170	*4170	2550	2750	1540	7.86
	lb					*10430	9190	*9190	5620	6060	3400	(25.8)
3.0 m (10 ft)	kg			*9740	6990	*6000	3820	4260	2410	2510	1370	8.19
	lb			*21470	15410	*13230	8420	9390	5310	5530	3020	(26.9)
1.5 m (5 ft)	kg					6540	3500	4090	2260	2460	1330	8.19
	lb					14420	7720	9020	4980	5420	2930	(26.9)
Ground	kg			*7660	6130	6320	3320	3970	2160	2600	1410	7.87
Line	lb			*16890	13510	13930	7320	8750	4760	5730	3110	(25.8)
-1.5 m (-5 ft)	kg	*7650	*7650	*11110	6180	6270	3280	3930	2130	3040	1660	7.18
	lb	*16870	*16870	*24490	13620	13820	7230	8660	4700	6700	3660	(23.6)
-3.0 m (-10 ft)	kg	*12010	*12010	*9250	6350	6360	3350			*3660	2330	5.95
	lb	*26480	*26480	*20390	14000	14020	7390			*8070	5140	(19.5)

Boom : 5.1 m (16' 9") / Arm : 2.6 m (8' 6") / Bucket : 0.76 m<sup>3</sup> (0.99 yd<sup>3</sup>) SAE / Outrigger and dozer blade down(CWT 2750kg, Front Position)

Load point height m (ft)		Load radius								At max. reach					
		1.5 m (5 ft)		3.0 m (10 ft)		4.5 m (15 ft)		6.0 m (20 ft)		7.5 m (25 ft)		Capacity		Reach	
														m (ft)	
7.5 m (25 ft)	kg												*3360	*3360	6.37
	lb												*7410	*7410	(20.9)
6.0 m (20 ft)	kg							*3250	*3250				*3360	2840	7.53
	lb							*7170	*7170				*7410	6260	(24.7)
4.5 m (15 ft)	kg							*3830	*3830				*3420	2380	8.20
	lb							*8440	*8440				*7540	5250	(26.9)
3.0 m (10 ft)	kg			*8540	*8540	*5530	*5530	*4400	3960	*2990	2700		*3510	2170	8.52
	lb			*18830	*18830	*12190	*12190	*9700	8730	*6590	5950		*7740	4780	(28.0)
1.5 m (5 ft)	kg			*7620	*7620	*6830	5960	*5010	3770	*3710	2620		*3620	2130	8.52
	lb			*16800	*16800	*15060	13140	*11050	8310	*8180	5780		*7980	4700	(28.0)
Ground	kg			*8230	*8230	*7570	5710	*5420	3630	*3250	2560		*3740	2230	8.22
Line	lb			*18140	*18140	*16690	12590	*11950	8000	*7170	5640		*8250	4920	(27.0)
-1.5 m (-5 ft)	kg	*7190	*7190	*11280	*11280	*7570	5620	*5430	3580				*3810	2560	7.56
	lb	*15850	*15850	*24870	*24870	*16690	12390	*11970	7890				*8400	5640	(24.8)
-3.0 m (-10 ft)	kg	*10590	*10590	*9950	*9950	*6760	5670	*4660	3630				*3700	3370	6.43
	lb	*23350	*23350	*21940	*21940	*14900	12500	*10270	8000				*8160	7430	(21.1)
-4.5 m (-15 ft)	kg			*6800	*6800										
	lb			*14990	*14990										

- Lifting capacity is based on SAE J1097, ISO 10567.
- Lifting capacity of the Robex Series does not exceed 75% of the tipping load with the machine on firm, level ground or 87% of full hydraulic capacity.

- The load point is a hook located on the back of the bucket.
- (\*) indicates the load limited by hydraulic capacity.

# Lifting Capacity

## R180W-9S

Rating over-front Rating over-side or 360 degree

Boom : 5.1 m (16' 9") / Arm : 2.6 m (8' 6") / Bucket : 0.76 m<sup>3</sup> (0.99 yd<sup>3</sup>) SAE / Outrigger and dozer blade up(CWT 2750kg, Front Position)

Load point height m (ft)		Load radius										At max. reach				
		1.5 m (5 ft)		3.0 m (10 ft)		4.5 m (15 ft)		6.0 m (20 ft)		7.5 m (25 ft)		Capacity		Reach		
														m (ft)		
7.5 m (25 ft)	kg													*3360	2440	6.37
	lb													*7410	5380	(20.9)
6.0 m (20 ft)	kg									*3250	2650			3030	1730	7.53
	lb									*7170	5840			6680	3810	(24.7)
4.5 m (15 ft)	kg									*3830	2570			2540	1410	8.20
	lb									*8440	5670			5600	3110	(26.9)
3.0 m (10 ft)	kg			*8540	7260	*5530	3870	4270	2420	2890	1590			2320	1250	8.52
	lb			*18830	16010	*12190	8530	9410	5340	6370	3510			5110	2760	(28.0)
1.5 m (5 ft)	kg			*7620	6340	6560	3510	4080	2250	2810	1520			2270	1210	8.52
	lb			*16800	13980	14460	7740	8990	4960	6190	3350			5000	2670	(28.0)
Ground	kg			*8230	6070	6290	3290	3930	2120	2740	1460			2390	1270	8.22
Line	lb			*18140	13380	13870	7250	8660	4670	6040	3220			5270	2800	(27.0)
-1.5 m (-5 ft)	kg	*7190	*7190	*11280	6060	6200	3210	3870	2070					2740	1470	7.56
	lb	*15850	*15850	*24870	13360	13670	7080	8530	4560					6040	3240	(24.8)
-3.0 m (-10 ft)	kg	*10590	*10590	*9950	6190	6250	3250	3920	2110					3630	1990	6.43
	lb	*23350	*23350	*21940	13650	13780	7170	8640	4650					8000	4390	(21.1)
-4.5 m (-15 ft)	kg			*6800	6490											
	lb			*14990	14310											

Boom : 5.1 m (16' 9") / Arm : 3.1 m (11' 1") / Bucket : 0.76 m (0.99 yd) SAE / Outrigger and dozer blade down(CWT 2750kg, Front Position)

Load point height m (ft)		Load radius										At max. reach				
		1.5 m (5 ft)		3.0 m (10 ft)		4.5 m (15 ft)		6.0 m (20 ft)		7.5 m (25 ft)		Capacity		Reach		
														m (ft)		
7.5 m (25 ft)	kg													*3000	*3000	6.96
	lb													*6610	*6610	(22.8)
6.0 m (20 ft)	kg									*2970	*2970			*3030	2530	8.02
	lb									*6550	*6550			*6680	5580	(26.3)
4.5 m (15 ft)	kg									*3420	*3420	*2310	*2310	*3110	2150	8.65
	lb									*7540	*7540	*5090	*5090	*6860	4740	(28.4)
3.0 m (10 ft)	kg			*7140	*7140	*4940	*4940	*4030	3980	*3220	2690			*3210	1970	8.95
	lb			*15740	*15740	*10890	*10890	*8880	8770	*7100	5930			*7080	4340	(29.4)
1.5 m (5 ft)	kg			*10650	*10650	*6370	6020	*4720	3770	*3890	2600					